

Important! Keep this.

Controlled by:

Guarantee number:

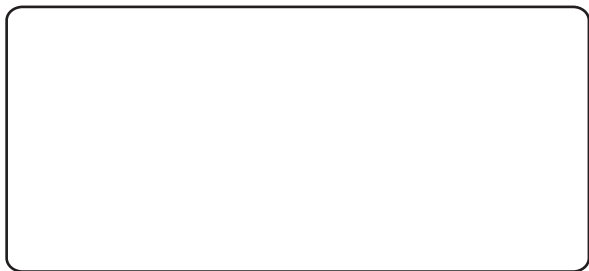

Lillevilla 448

3000 mm x 4000 mm / 44 mm

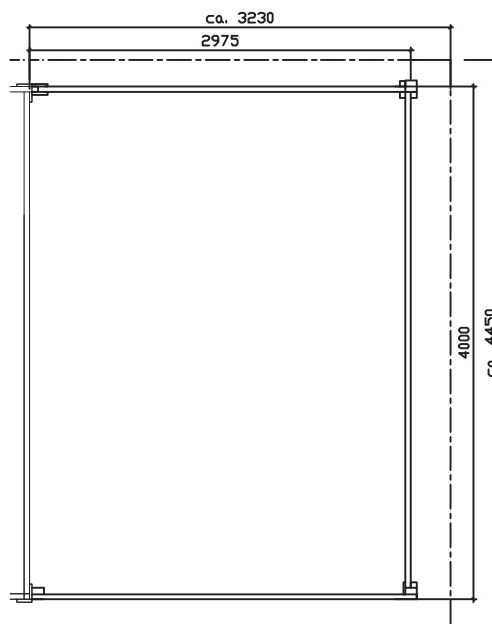
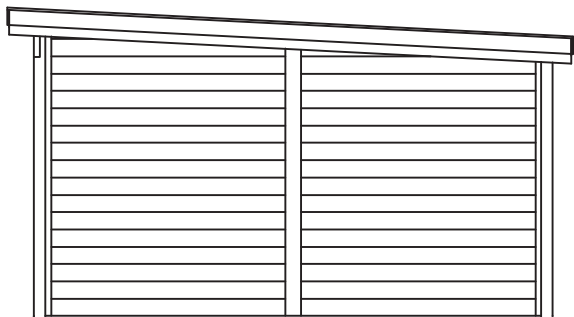
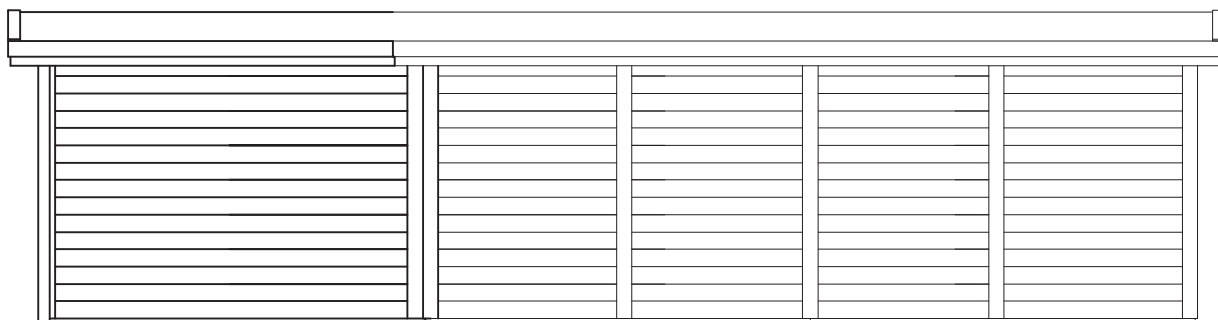
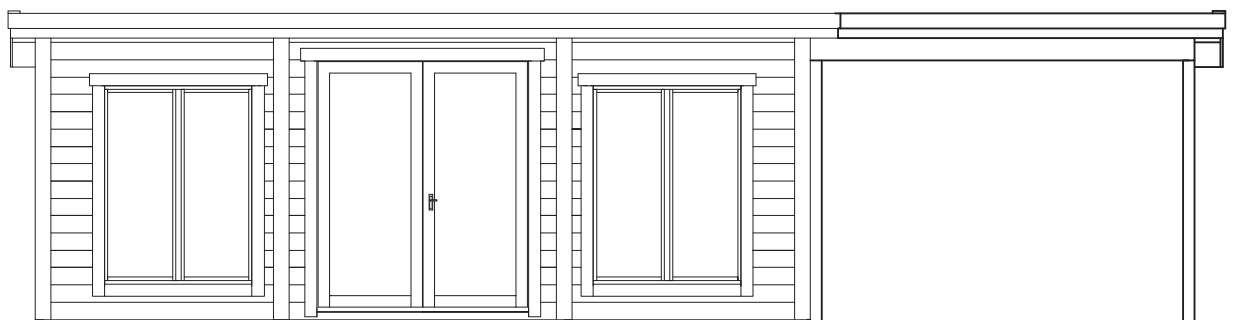



Lillevilla 448

3000 mm x 4000 mm / 44 mm

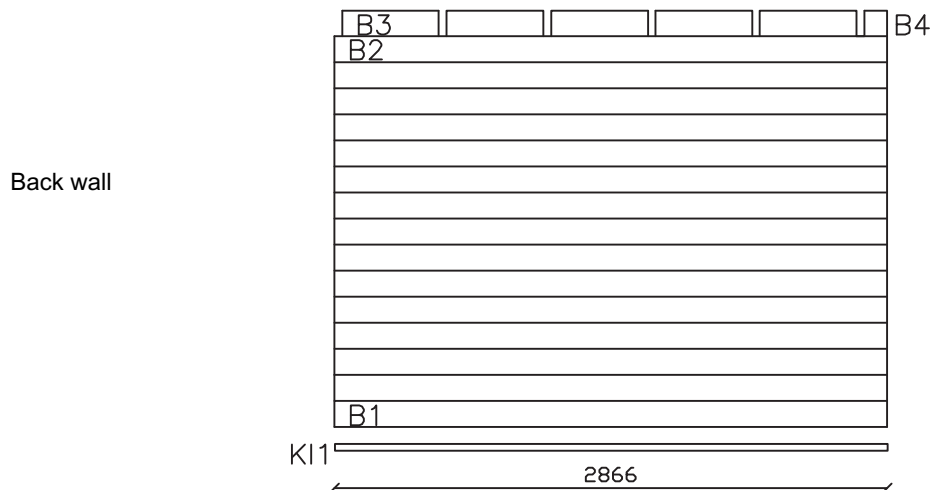
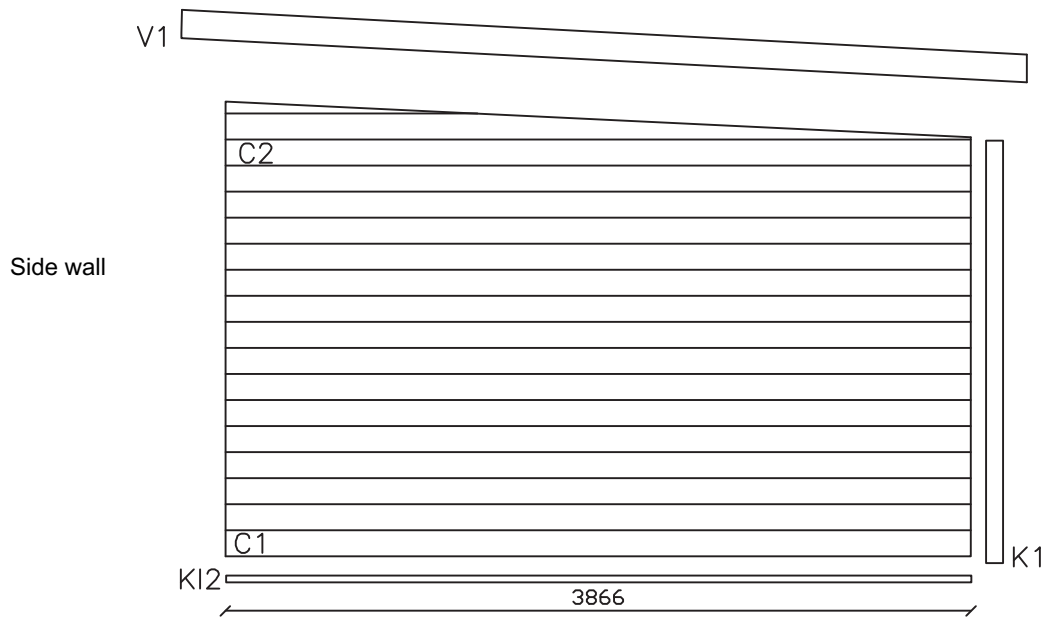
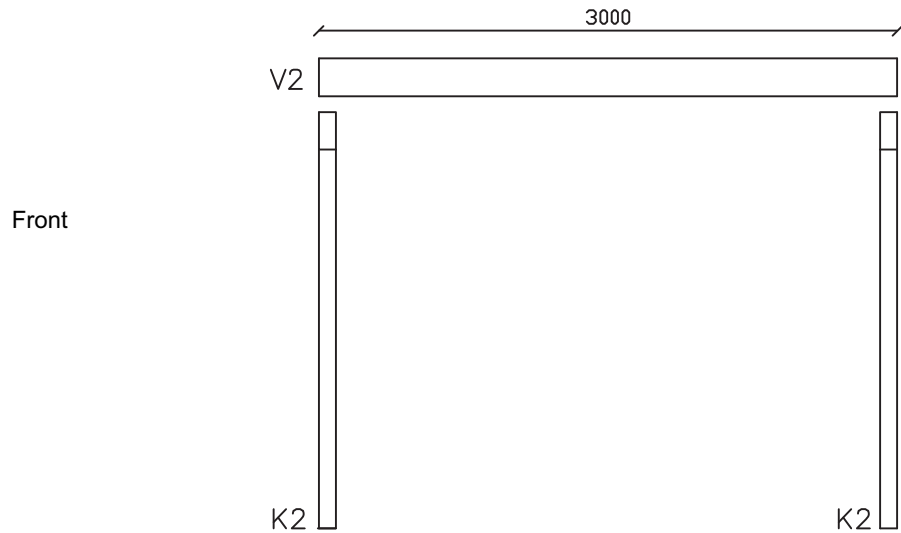



Lillevilla 448

3000 mm x 4000 mm / 44 mm

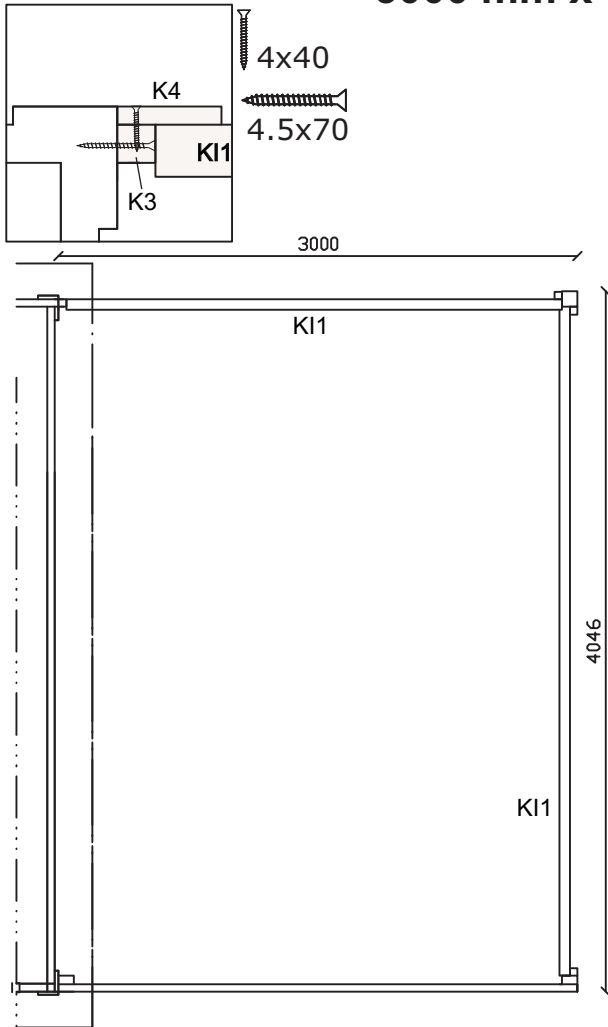

Fix the wall supports to the posts with 4.5x70mm screws.

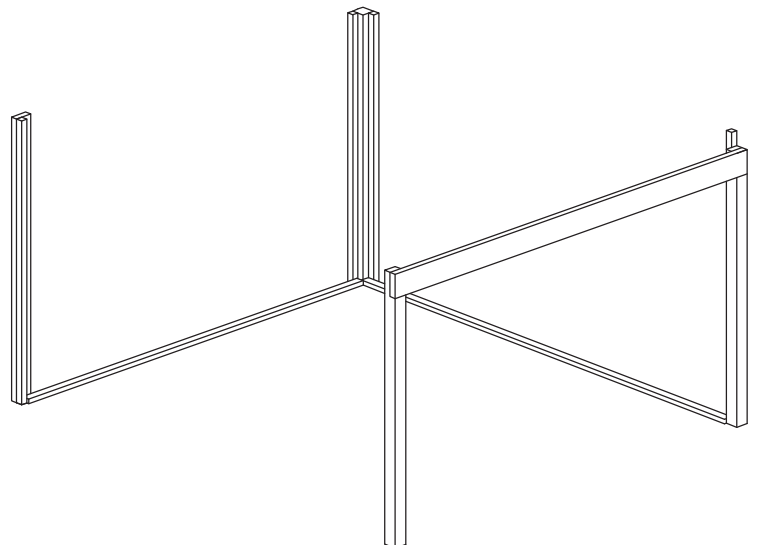
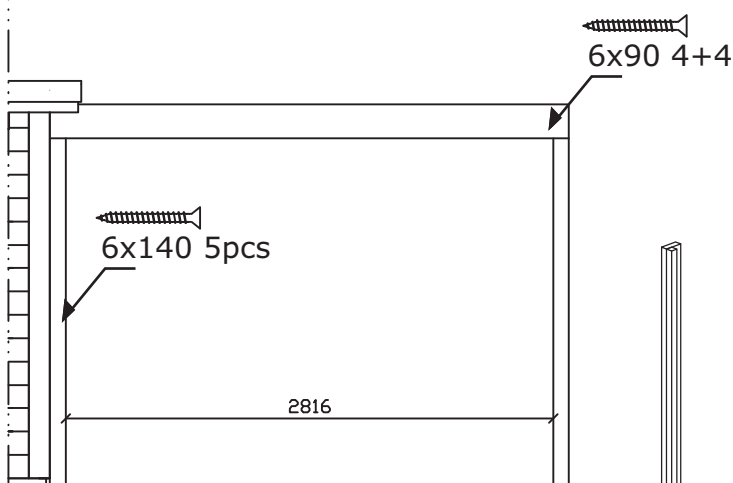
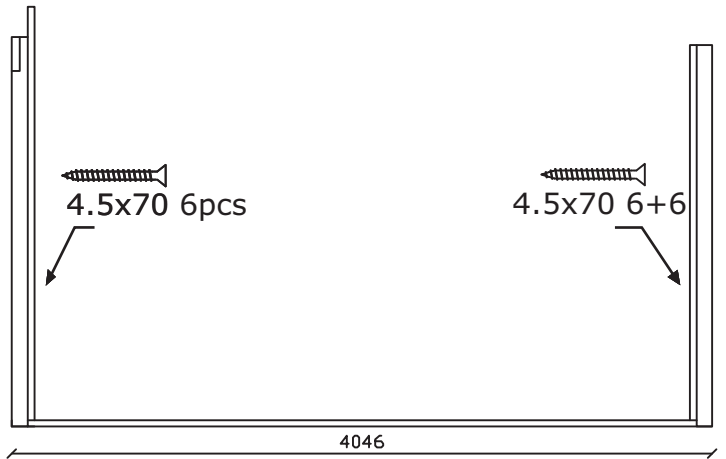
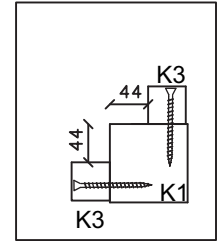
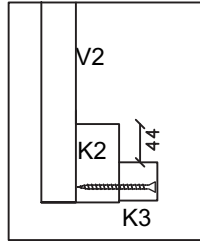

Read through the whole manual before you start building your cabin.



Lillevilla 448

3000 mm x 4000 mm / 44 mm

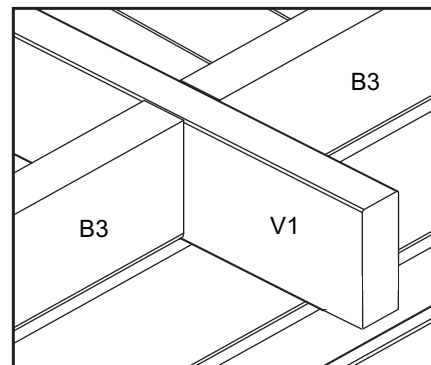
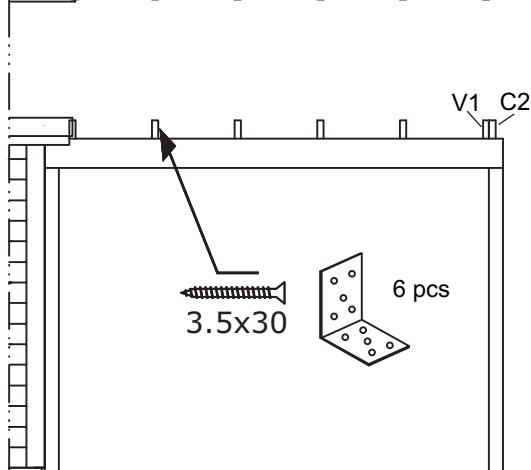
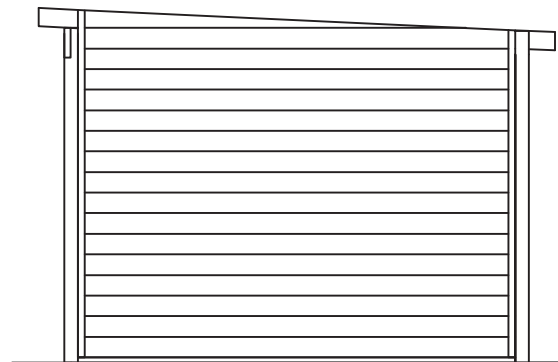
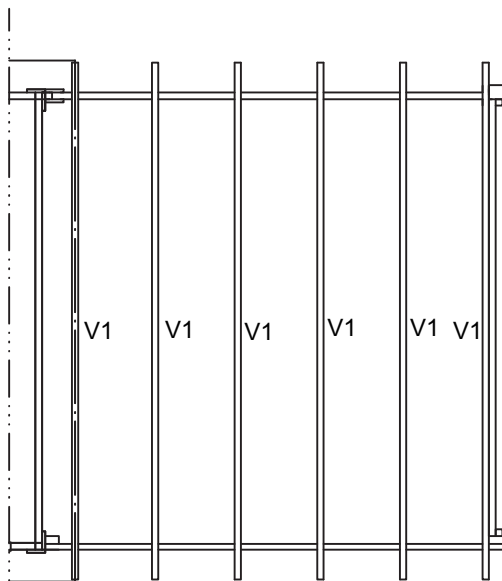
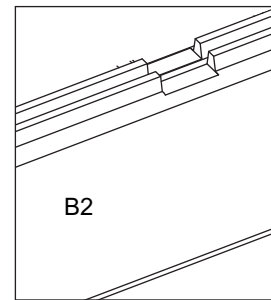
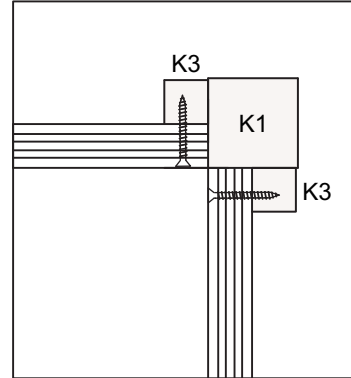
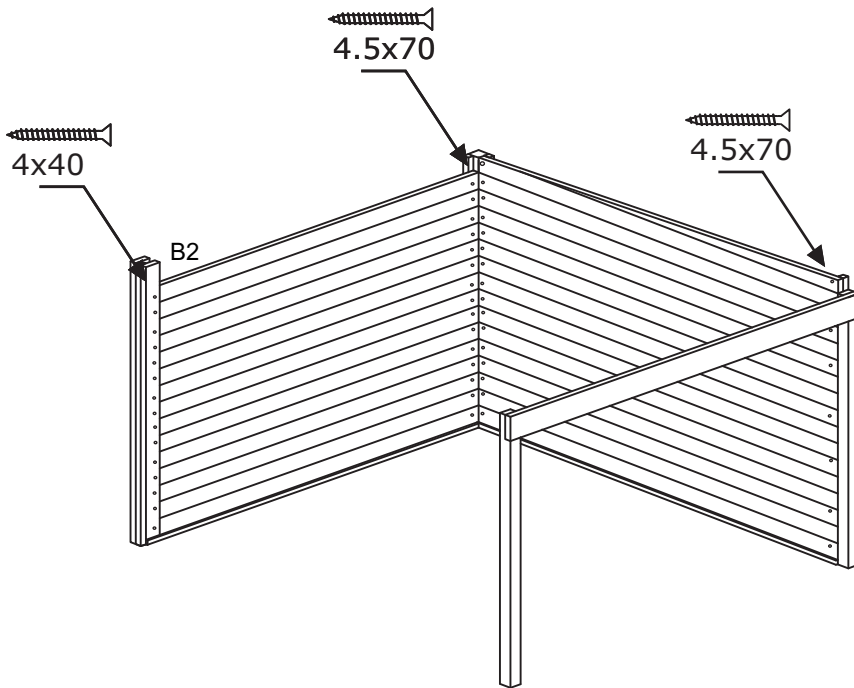



Lillevilla 448

3000 mm x 4000 mm / 44 mm

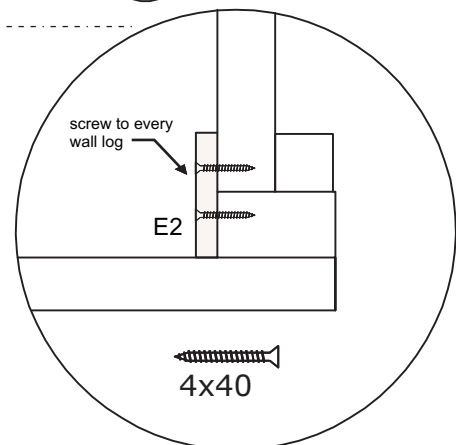
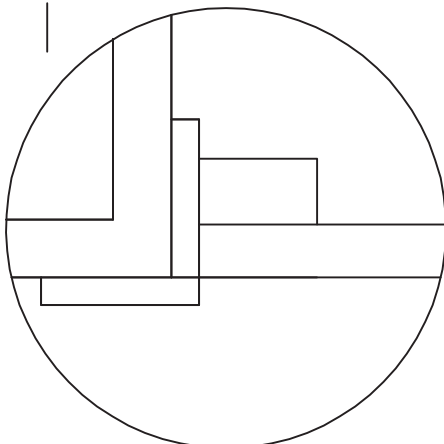
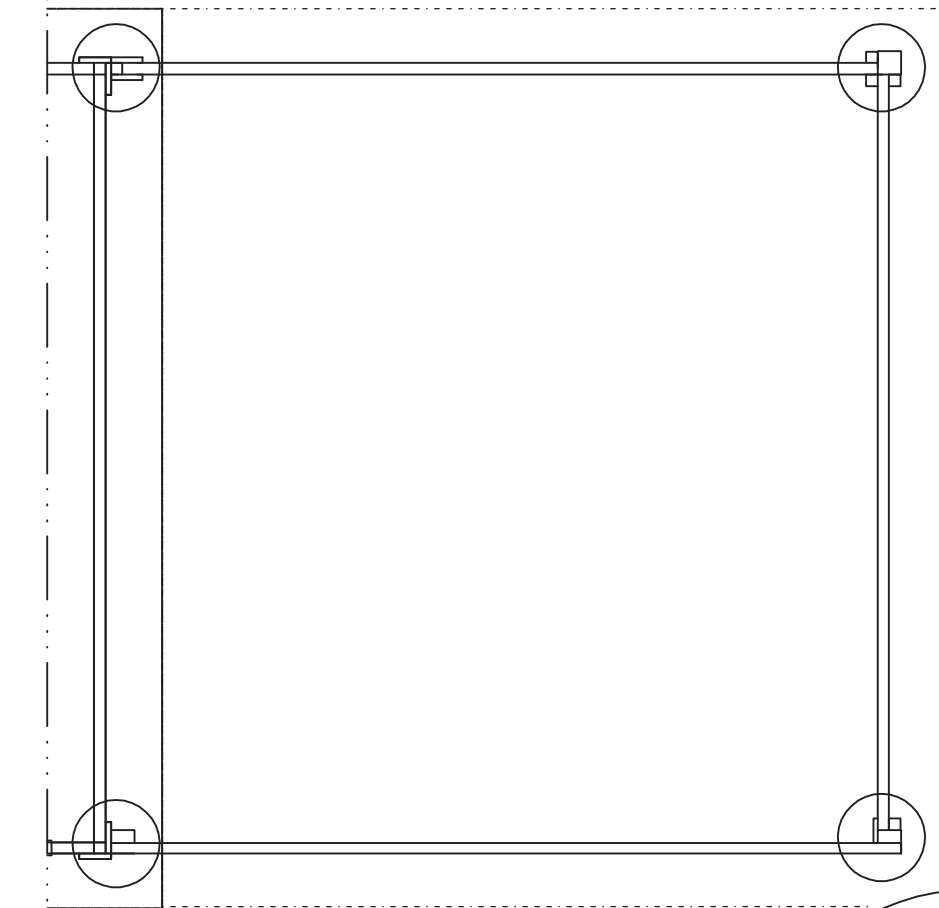
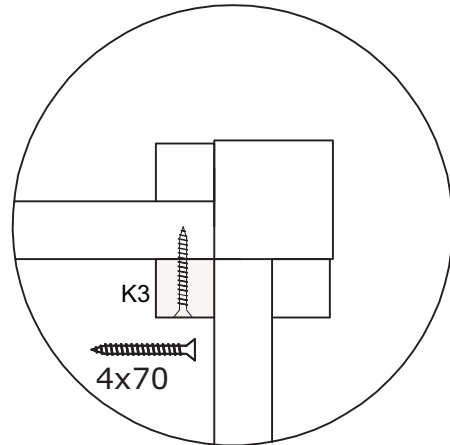
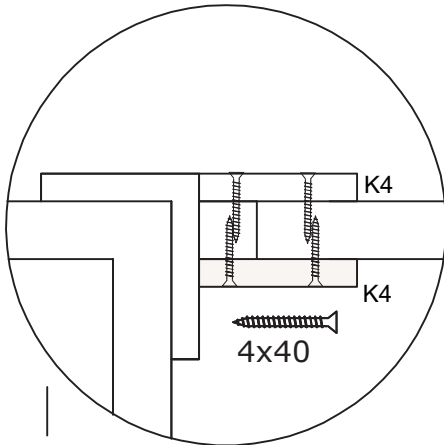



Lillevilla 448

3000 mm x 4000 mm / 44 mm

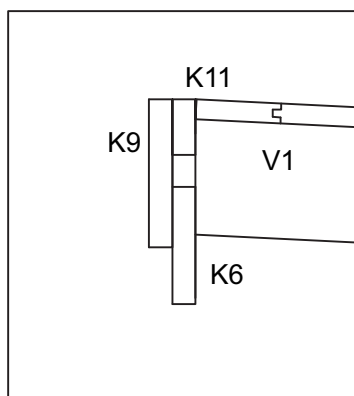

Install the wall support to the side wall screw 4.5x70 to every wall board

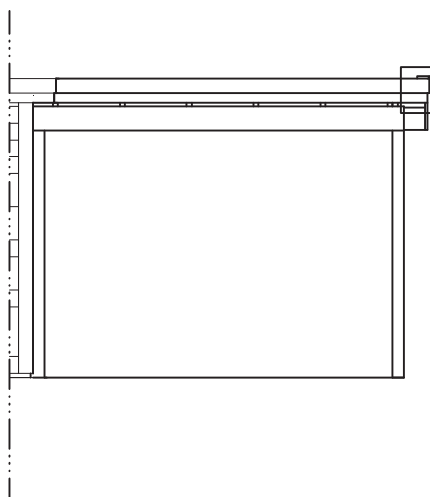
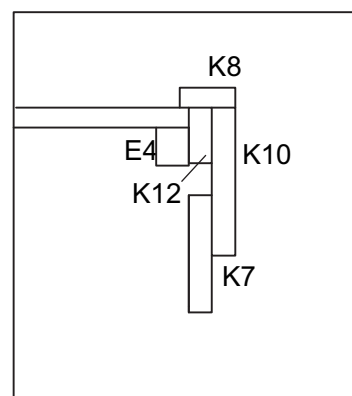
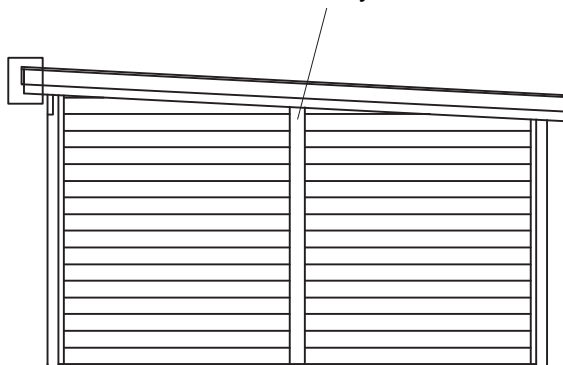

If you are use EPDM membrane for roofing, please raise the fascia boards as shown.

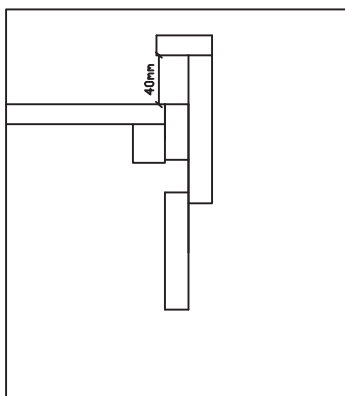
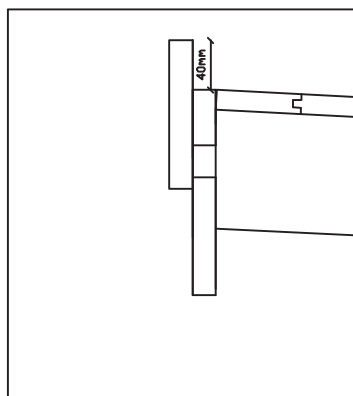



Lillevilla 448

3000 mm x 4000 mm / 44 mm

List of parts

Part	Dimensions in mm.	Pcs	Mark	Control
Foundation beam	36 x 60 x 2866	1	K11	
Foundation beam	36 x 60 x 3866	1	K12	
Roof board	16 x 87 x 3050	51	KA1	
Corner post	90 x 90 x 2205	1	K1	
Corner post, with cut-out for beam	90 x 90 x 2251	2	K2	
Wall support, to be cut at site	44 x 44 x 2380	5	K3	
Cover board to corners, to be cut at site	21 x 120 x 2380	2	K4	
Fascia board, front and back	16 x 95 x 3050	2	K6	
Fascia board	16 x 95 x 4394	1	K7	
Wind covering board	16 x 95 x 4452	1	K8	
Fascia board, front and back	16 x 120 x 3068	2	K9	
Fascia board	16 x 120 x 4426	1	K10	
Support to fascia board	16 x 45 x 3050	2	K11	
Support to fascia board	16 x 45 x 4394	2	K12	
Log	44 x 135 x 2866	14	B1	
Log	44 x 135 x 2866	1	B2	
Log	44 x 145 x 502	5	B3	
Log	44 x 145 x 118	1	B4	
Log	44 x 135 x 3866	15	C1	
Gable triangle	44 x 333 x 3866	1	C2	
Wall support to side wall	40 x 120 x 2280	1	C3	
Cover board to side wall, inside, to be cut at site	16 x 145 x 2380	1	E2	
Support to fascia board	26 x 31 x 4300	1	E4	
Roof beam	40 x 145 x 4394	6	V1	
Horizontal beam	45 x 195 x 3000	1	V2	
Screws, nails etc.		1	T2	
Piece of log for fitting	44 x 65 x 250	2	T3	

All measurements approximately.
We reserve the right to make technical changes.



GENERAL INSTRUCTIONS FOR BUILDING UP THE LILLEVILLA

Dear Lillevilla owner,

Thank you for choosing the light log cabin building from Luoman Puutuote Oy. These general instructions concern all our light log items of 19, 21, 28, 34 and 44mm. Please read the instruction manual carefully in full before beginning the installation and keep the instructions for further reference. Drawings of wall constructions and part lists are specific to each model's own separate instructions.

In a case of reclamation, please inform your dealer about the specific guarantee number of your cabin. You can find this code on the package and on the first or last page of the instruction manual. Unfortunately, without this guarantee number we cannot handle your reclamation!

NOTE: Luoman Oy reserves all the rights to the photos, drawings, building instructions and other technical information. Using or forwarding them for competitive purposes is forbidden and will be followed by legal action.

Luoman Puutuote Oy has a Chain-of-Custody system, which is certified by DNV Certification Oy/Ab (www.dnv.com, certificate 2149-2005-SMS-HEL-DNV). At www.luoman.fi we present the share of certified wood raw material in your cabin. Our company is a holder of the PEFC logo license PEFC/02-31-82.



1. Storage of cabin package at the site, sorting and checking parts

Machined logs and other parts have been protective wrapped. If the item will not be immediately constructed, it should be kept indoors or otherwise well protected until ready to be installed. The package should be kept away from the ground to avoid absorbing moisture and stored on a level base.

Building instructions include a parts list and drawings of the wall construction.

Please check the contents in full with the help of the parts list and contact your retailer immediately if something is missing or defective.

Please sort the parts near the planned building area leaving enough space for working (Drawing 1).

2. Planning permission

Please check with your local building authorities if planning permission is required before beginning construction.

Note: Some building knowledge and experience is required when erecting a Lillevilla. If necessary, please ask for advice or help from someone professional.

3. Foundation

The most important aspect of the construction is the foundation. This must be flat, completely level and devoid of any movement. Take care when building on areas where the ground retains water.

In all cases a concrete raft foundation is preferred (Drawing 2) this spreads the constructions' load over a wide area and suits all ground types. Your retailer can advise an alternative foundation method should a raft not be possible.

The foundation for the optional terrace must be level with the base for the cabin and be prepared carefully. When erecting a model equipped with threaded rods, before making the foundation please read section 9 Protection against storm.

4. Building up

4.1. Foundation timber

Begin the construction by assembling the foundation beams at equal distances apart (unless otherwise specified) across the area of the base according to the separate foundation drawing. Fasten them to the foundation, for example with angle irons (excluded). Foundation beams are protection treated but it is advisable to add a roofing felt strip (excluded) or another insulator between the foundation and the beams to stop moisture from the foundation penetrating the timber.

The outermost foundation beams should finish nearer each other than the log walls (Drawing 4). There are two important reasons for this. 1. Rain water won't wet the point of contact of the foundation beams and the lowest logs. 2. The outermost foundation beams offer support for the edge of the floor.

4.2. The cabin without floor

If your cabin excludes a floor and you are building the log frame directly onto brick/blockwork, please add a felt

bitumen strip between the undermost log and brick/block. Additionally the brick/blockwork should be 5-10mm smaller than the log frame so that rain water falling along the walls won't wet the point of contact at the lowest log.

4.3. Building up the log frame

When building up the log frame please use the wooden blocks for assembly, these are marked with the letter X. Place the block on top of the log tongue and hit the assembly block so that the log goes to the bottom (interlock). Use only slight knocks to avoid breaking the logs. If the log doesn't easily fit into place, check that it is straight on the groove joint of the lower log. The logs are machined accurately and should require little force when assembling.

Begin building the log frame by installing the undermost log layer on top of the foundation beams. **Note:** Assemble the tongue joints upwards. Check the diagonal measurement of the log frame (Drawing 5) and then fasten the lowest logs into the foundation timber with nails or screws (Drawing 6). Remember to pre-drill to avoid splitting the log. If the cabin excludes a floor and foundation beams, fasten the log frame to the brick/blockwork with angled brackets (excluded).

Continue building up the walls one log layer at a time according to the wall construction drawings. **Note: when building a cabin including both drilled and un-drilled logs of the same length, they must not change position by mistake otherwise you will not be able to install the threaded rods.**

5. Installing the door and window

5.1. A single door

A single door has usually been pre-assembled in its frame. The frame including the door will be slipped into its place from the upper side of the opening (hinges outside), Drawing 7. Door frames are machined so that the logs fit into the channel on the sides. If the frame does not easily go into its place, check that the log ends going to the groove are straight. You can gently knock the frame into place using a hammer and assembling block to avoid breaking the frame. Fasten door handles and check that the door is functioning properly. Fit the lock by sliding it into place, aligning the holes for the fastening screw. Tighten screw initially by hand ensuring that you do not cross the thread.

5.2. Double door

The frame of the double door is packed as parts and must be assembled before installing (Drawing 8a and 8b). Fasten the side and the top part of the frame together by nailing or screwing at the corners. Make sure that the joints of the frame are properly fastened without showing gaps. If there is a metal threshold, screw it to the bottom end of the frames sides. **Note:** The distance between sides of the frame must be exactly the same at the top and the bottom. Fit the frame from the upper side of the opening in the same way as the single door. Check the diagonal measurement of the frame and lift the doors onto their hinges. Fasten the door handles and check that the doors are functioning properly. Fit lock as instructed for single door.

5.3. Remarks about doors

Note: It is very important that the cabin and the door frame are completely level to allow the door(s) to function properly. The log under the door frame cannot always be produced to sit completely level, so take this into account when assembling the door frame and if needed add some packing. Then nail the side frame to the lowest log only so that you do not impede the settlement of the building.

Because timber expands and contracts with changes in air moisture content, it is sometimes necessary to adjust the

door hinges by turning them inward or outward, depending on the situation. For example, if the door seems to be too big compared with the frame, rotate all the hinges inward.

5.4. Assembling the window

Windows are slid into place from the upper side of the opening in the same way as the door. Screw the window handle in place and check that the window is functioning correctly. **Note: Be careful to install windows the right way up. Windows assembled upside down will fall from the hinges when opened.** Some windows are to be assembled with hinges at top. Avoid opening such too much, because it might also loosen from the hinges.

5.5. Settlement allowance above the doors and windows

When building up the walls, you will note that there is a few centimetres space above the door and window (Drawing 9). Because wood is a living material, it shrinks in dry conditions (log frame goes down) and expands due to moisture (log frame rises). That is why the allowance for sinking is so essential – it lets the walls move without damaging the construction. The space is hidden with cover board nailed only to the frame of door/window. Never nail it to the log; this would prevent the natural movement of the log construction. For the same reason frames of doors and windows are not to be nailed to the log wall at any other place, other than the lowest log (the only exception is models having 19mm wall thickness, please see chapter 9. Protection against storm).

6. Gable triangles and supports of the roof (purlins)

Please note that the uppermost logs of the side walls are bevelled to follow the inclination of the roof and they don't have a timber blocking on their upper side. When the walls are complete you will need 2-3 persons to install the gable triangles. Check that the side walls are vertical; sometimes they need to be pushed slightly inwards to get the gable triangle to fit. **Ensure that the gable triangles are not left unsupported before installing the ridge purlin.** The purlin should be slid into the notches of the gable triangles so that the upper edge is flush with the edge of the triangle. Other purlins can then be installed in the same way, then pre-drill and nail the gable triangles to all the purlins. Screw the uppermost side wall logs to the gable triangles using 2 screws/corner (pre-drill!). Drawing 10.

6.1. Gable triangles consisting of several parts or separate logs

Gable triangles for some models consist of several parts or separate logs (please see the drawings of wall construction). Assemble the gable triangles following the drawings and fasten the parts together with 100mm nails (countersink nails 1-2mm into the logs).

7. Floor

These instructions are for cabins including floorboards and foundation beams: Floorings have been planed to profile. They have tongue-and-groove joints and the back side is bevelled and has two furrows. It is normal that the back side has wane on it. It is not a defect but a characteristic of the product, normally boards will have only one face side.

Begin assembly by fixing the first floorboard with the bevels and furrows downwards onto the foundation beams with the groove joint towards the wall (leave about 5mm space between the wall and the floorboard). Mark with a pencil the centres of the foundation beams on the bottom of the wall log. This makes it easier to find the nailing line. Put all the floorboards in place. Note: Flooring will expand and contract depending upon the amount of

moisture in the air, so leave a space of 1-1.5mm between each board. If needed, saw the last floorboard down to fit in place.

When the floorboards are in place, follow the marks you made on the walls and nail the floorings to the foundation timber (Drawing 4). Using a line or board may help. Fasten the skirting boards to the wall and not to the floor. Protect the floor immediately upon completion to keep it clean.

8. Roof

8.1. Installing the roof boards

Before proceeding to the roof stage, ensure that the log frame is correct and the doors and windows are working properly. If threaded rods are included, they must be installed before the roofboards.

Roofboards have the same profile as floor boards; lightly bevelled edges on the front and visible side (assembly downwards) and bigger bevellings and furrows on the back, invisible side (assembly upwards).

The back side usually has wane on it. Again this is not a defect but a characteristic of the product and like the floorboards, these have only one good side.

Drawing 11. Begin nailing the roof from the front. Fix the first boards on both sides of the roof and make sure that they sit flush with the edge of the purlins. Nail the boards both to the side walls and all purlins. Leave 1-1.5mm space between each roofboard to allow them to expand and contract with moisture. Use the centre line of the ridge purlin as a guide to keep the roofboards straight. Measure and trim the last roofboard to fit flush with the ends of the purlins. Trim cut the bottom line of the roof straight. Then fix the fascia boards according to Drawing 12A.

If the cabin includes roofboards of two different lengths, install the long one first starting from the front and then alternate the short and long boards.

8.2. Covering material for roof

Covering material for the roof must be installed immediately. If this is excluded, temporary protection is required. Only light material, for example bitumen shingles or lightweight steel are suitable roof coverings. The load on the roof boards should not exceed 100 kg/m².

Fascia and barge boards should be installed after the roof covering is fitted (Drawing 12B). If the cabin model includes two sets of fascia boards, install the widest first followed by the narrower ones.

8.3. Roofing felt

If roofing felt is included, measure the length of the roof and cut the exact same length from the felt. Fasten the first length carefully to the eaves (Drawing 13). You can leave the edge of the felt about 0.5-1 cm over the eaves, but do not bend the felt. Overlap the next felt strips a maximum of 30mm and do the same on the other side of the roof. Finally, install the felt strip on top of the ridge. **The roofing felt included in the delivery is for temporary use only and it must be replaced with suitable covering material, for example, shingles within six months.**

8.4. Roofing shingles

Drawing 14. The bitumen shingles are to be attached directly to the roof boards. They should be fitted when the

ambient temperature is above +5C. The surface of the roof must be dry and clean. Please ensure all roofboards and the long fascia, which is attached to the bottom edge of the roof, have been fitted. (Pic A)

The eave strips must be installed first. Make these strips by cutting off the hexagonal part of the tile (or tab), in order to leave a rectangular strip. (Pic B). (Note: keep the tabs as they will be required later.) Leave the eave strip 1-2cm over the roof's edge to allow water to run off. (Pic C).

Remember to remove the covering film from the underside of the shingles.

Start the installation of the shingles from the centre of the roof at the eaves and work out to the sides. At the ends of each row cut the tile to the edge of the roof. Then use this off cut to start the next row at the opposite end. (Pic E) Fasten shingles with the clout nails provided. Use four nails per tile, nailing 2cm above the middle edge of the tile. (Pic 14D) After nailing the first row of shingles, position the next course so that the hexagonal part of the tile covers the nails and joints of the previous row.

Cover both sides of the roof up to the top (about 5cm from the ridge can be left uncovered). You will now need to use the 'tabs' to cover the joint where the last row of shingles butt end to end and complete the hexagonal pattern up to the top of the ridge. Fit the ridge strip using clout nails approximately every 10cm. (Pic F) (Alternatively use a heat torch to fix the ridge strip, so that the nails are not visible.)

When you have finished fitting the shingles, fix the wind covering boards and front fascia. It is easiest to nail these together first then offer them up to the roof and secure them through the fascia and into the purlins. (Pic G).

9. Protection against storm

Although your Lillevilla cabin is a solid construction, it is worth protecting it against heavy winds. Fasten beams to the foundation as previously described.

Note: Fasten the roof to the building and the cabin to the foundation and take special care in open areas where there is the possibility of heavy winds and storms. You will need extra fastening material excluded from the delivery.

9.1. Storm battens, wall thickness of 19mm

Fasten storm battens to each inside corner of the building by nailing them to the lowest log of the gable triangle and to each wall log (nails are included in the delivery). Also nail frames of window and door to each wall log (concerning only 19mm cabin). Drawing 15.

9.2. Storm battens, wall thickness of 21, 28, 34 and 44 mm

Drawing 16. If storm battens are included in the delivery, fasten them to each inside corner of the building. Fasten the upper end only to the lowest log of the gable triangle and bottom end only to the lowest wall log. The storm batten has a small hole at the bottom and a slot at the upper end. Use a 6mm drill to make the holes to the lowest log of gable triangle and the wall. Use bolts to fasten the batten (place nut inside). Do not over tighten the upper bolt, hand tight is sufficient so as to enable the log frame to move freely up and down depending on the moisture content of the air.

Take care that there is enough space between the upper end of the storm batten and the roof to avoid them touching each other when the walls move down.

9.3. Threaded rods

Drawing 17. If threaded rods are included, slide them into the ready drilled holes in the corners of the building according to the drawing (nut and washer to both ends). Please take care that the upper end of the threaded rod is below the level of the gable triangle so as not to impair the level of the roofboards. Check the nuts regularly and tighten lightly when needed. It may be necessary to loosen the nuts a little to allow the expanding timber to rise when the weather is damp, otherwise the walls will try to bow out in the centre of the building.

When the house frame settles, it is possible that threaded rods may touch the ground and begin to push up the roof. Note this point when installing the foundation and ensure you have adequate space between the base and the bottom of the rods, otherwise the rods may need to be shortened.

10. Assembling the terrace (optional)

Begin by fastening the foundation beams (T14) in place in the same way as you did with the building itself. The short foundation beams (T15, if included) should be placed under the parapets at the sides of the entrance to the terrace. They also act as a base for the first floorboard.

The two half logs (T5) should be assembled on the outermost foundation beams so that the logs overhang the edge of the beam making it possible to fasten the ends of the terrace boards to the foundation beams, in the same way as the cabin floor. Install the parapet logs according to the drawings, then set the floorboards (T16) at an even distance apart (1 cm between each board) on the foundation beams. When they are all spaced out evenly they can be nailed. It is normal that the bottom of the floorboard has wane on it. This is not a defect but a characteristic of the product. Boards will normally have only one good side. The short floorboard belongs between the two parapets, in the entrance to the terrace. Note: If threaded rods are included, it is advisable to screw the first three floorboards next to the cabin so that they can then be removed easily to adjust the nuts of the rods.

Screw the parapets of the terrace to the floor using the angle irons (T13). Then finish the parapets by fastening the balustrades (T9, T10) to them and assemble the U-profiles (T11) to both sides of the entrance. Fasten the facing plank (T18, if included) in front of the foundation timber. Finally, fasten the parapets to the building with four T12 boards.

11. Finishing of the building

11.1. Window crosses

If the window crosses of your model are unfastened, please nail or screw them to the door/window. Pre-drill small holes about 1 cm from the end of the cross and fasten the crosses carefully (Drawing 18). Note that about 10mm of the glass reaches into the door/window frame.

Most models have readily assembled crosses fastened with plastic cleats. These can be unfastened for washing the glass.

11.2. Equipment for keeping the window open

Some models include equipment for keeping the window open. The installation instruction is in the bag of accessories.

11.3. Protection plastic of plexiglass

Windows and doors of some models have plexiglass. They have protective plastics to avoid scratching during the production process. Remove them after assembling the window/door.

12. Protection treatment

Treatment must be performed immediately after erecting the cabin. Please follow the instructions from the treatment manufacturer. The best result will be achieved in dry conditions when the temperature is over + 5 C. Treatments both in and outside must be renewed regularly following the manufacturers instructions. Follow carefully the condition of the south side wall as ultraviolet radiation affects it more than the other walls.

Despite treatment, moisture can get in through corners, knots, splits and joints of the parts. This can be prohibited with silicon. Note: split knots of light log cabins can allow protection material to bleed through to the inside. Water is absorbed into the wood construction easiest through the ends of the logs and the ends of the fascia boards, so treat these areas often and with care. Other timber parts being under heavy strain of weather and wear include wind covering boards, parapets and facing planks of the terrace. These should be treated often, yearly if necessary.

Protect the floor of the terrace during the treatment of walls. Also treat the internal floor with lacquer or paint before use.

13. Care and maintenance

Safe long-term use of the building requires regular checking, possible reparation of the fastenings and inspecting the condition of the parts. Pay particular attention to the roof construction, covering material, doors and windows, foundation fastenings, the protection against storm and surface treatment. Failure to perform regular maintenance can cause damage to the building or a safety risk to the user.

Regularly inspect the condition of the exterior treatment and re-new it when necessary. Inspect the bottom of the doors, windows and their frames, end surface of timbers and parts stressed by hard wear.

Check the functioning of doors and windows and adjust hinges when required. Check the silicon seals of doors and windows, renewing when necessary.

It is very important to make sure that underneath the cabin is well ventilated.

14. Some tips for possible problematic stages

If the doors or windows do not seem to fit correctly in the opening, check the level of the foundation and the level of the building. These components will not function properly if they do not sit level, if necessary pack up the low corner to correct this fault.

If the side and end walls are at different heights when they are completed, check that all the logs are down correctly in their tongue-and-groove joint. You can rectify this by lifting the uppermost log of the lower wall to the right level and by fastening it to the log of the connecting wall. Then knock the lower logs up one by one and even out the spaces.

This is not a machining fault, it is due to the moisture content of the timber and will rectify itself in due course.

1. Osien lajittelu - Sorting the parts - Sortering av delarna - Sortering av delene - Le tri des pièces - Selezione dei pezzi

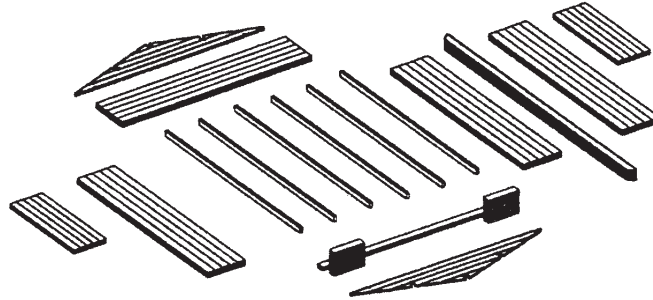

2. Laattaperustus - Concrete raft foundation - Betonggrund - Betonfundament - Les fondations avec la dalle -
 Le fondazioni con una lastra di cemento

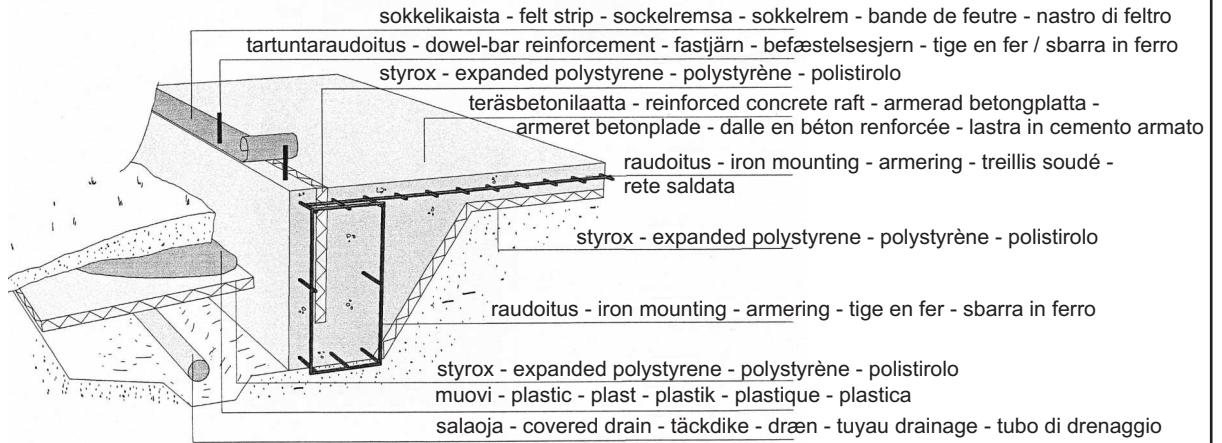

4. Hirsien asennussuunta, perustuspuiden asettelu ja lattian kiinnitys - The assembling direction of logs, foundation beams and assembling of the floor - Monteringsdirektion av väggtimren, grundbalkarna och montering av golvet - Vægbrædderne, fundamentbjælkerne og montering af gulvet - La pose des solives et la fixation du plancher - La posa delle travi di fondazione - Prusside paigaldussuund, vundamendiprusside paigaldus ja põranda kinnitamine

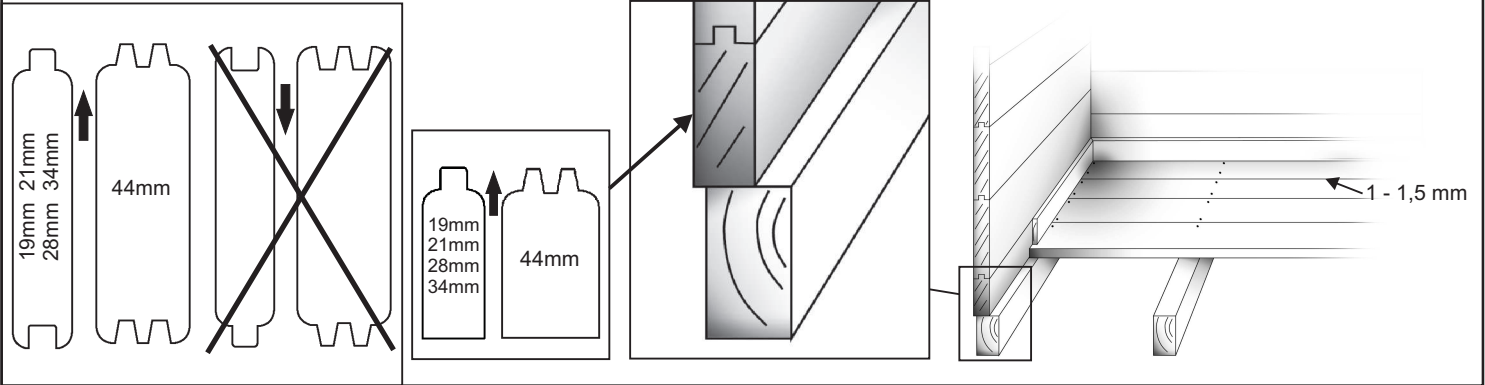

5. Kehikon ristimitan tarkistaminen - Checking the diagonal measurement of the log frame - Kontroll av diagonalmått hos timmerramen - Krydsmåling af bjælkerammen - Control de diagonal de la structure - Controllo diagonale della struttura

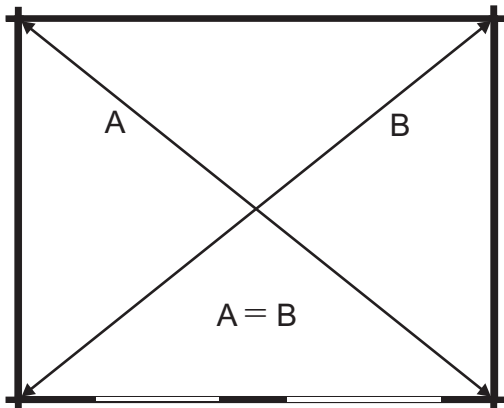

6. Alimpien hirsien kiinnittäminen - Fixing the lowest logs - Fästning av det första timmervarvet - Fastgørelse af de nederste bjælker - La pose des premiers madriers - La posa dei primi tavoloni

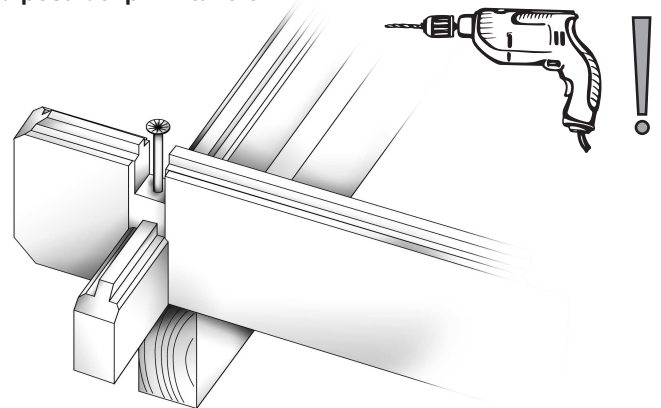

7. Oven asentaminen - Assembling the door - Montering av dörren - Montering af døren - La pose de la porte - La posa della porta

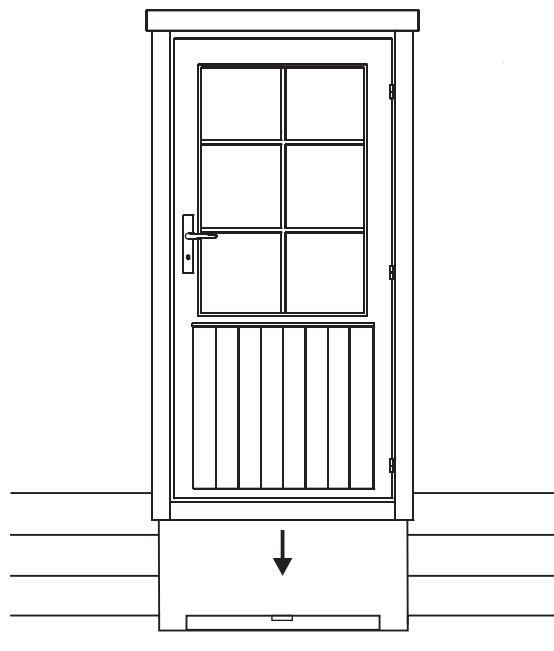

8a. Parioven karmien asentaminen - Assembling the double door frames - Montering av dubbeldörrens karm
Montering af fløjdørens karme - La pose du cadre de double porte - La posa del telaio della doppia porta

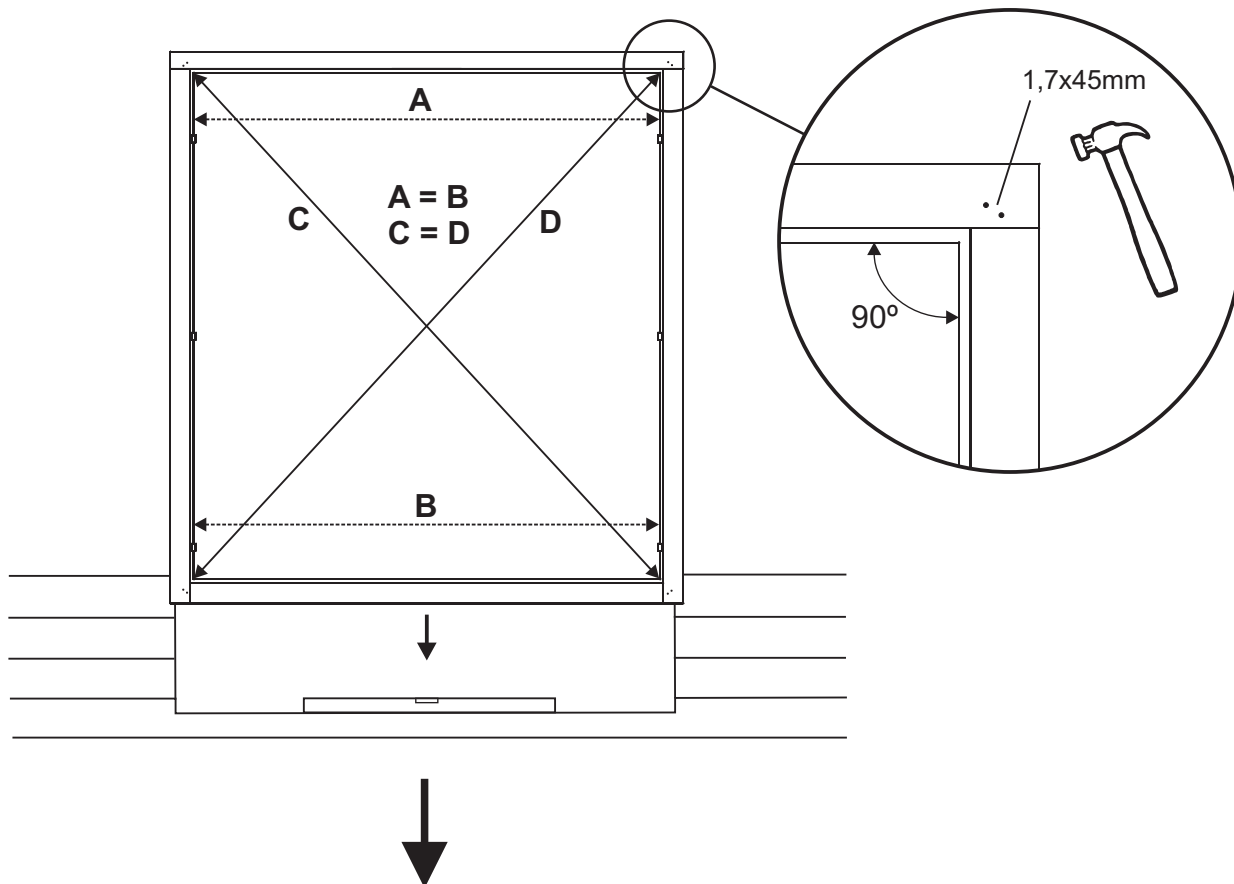

8b. Parioven asentaminen - Assembling the double door - Montering av dubbeldörren - Montering af fløjdøren -
La pose du double porte - La posa della doppia porta

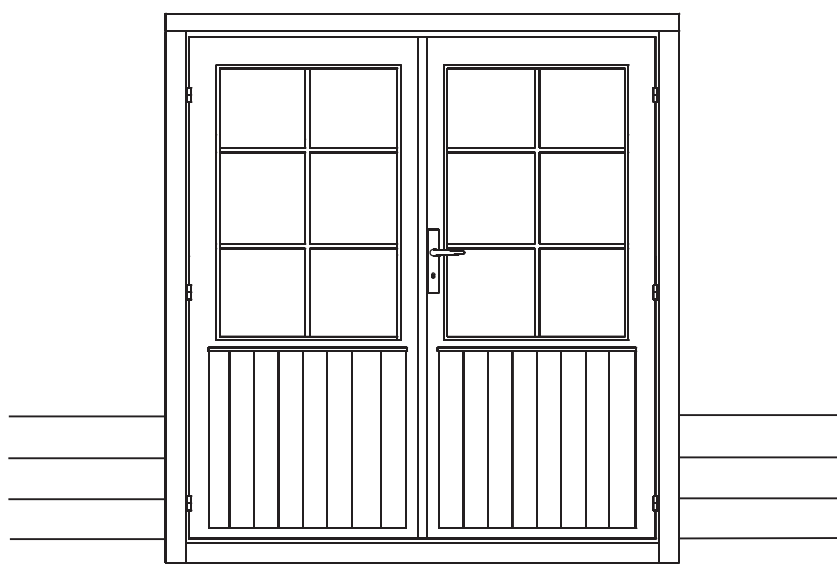

9. Painumavara ikkunan/oven päällä ja peitelaudan asentaminen - Space for settling above window/door and assembling the covering board - Sänkingsmån ovanför fönster/dörr och montering av täckbrädan - Plads til sætning over dør/vindue og montering af dækplade - L'espace dessus de la fenêtre et de la pose du couvre joint - Lo spazio sopra la finestra e la porta ed la posa delle copri giunture

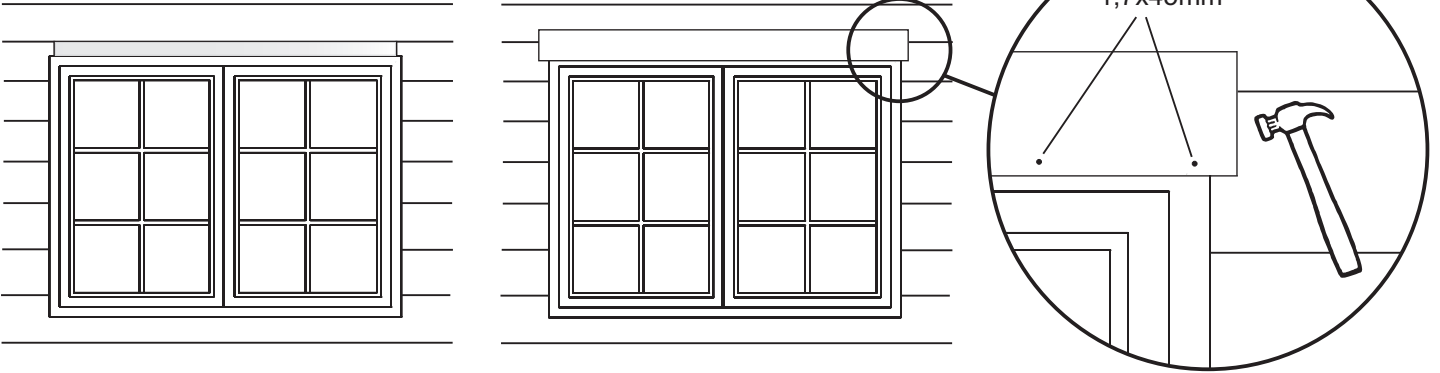

10. Päätökolmio, sivuseinien ylimmät hirret + kurki/vierrepuut - Gable triangles, uppermost logs of side walls + purlins - Gaveltrianglarna, översta väggtimren på sidoväggarna + takbalkarna - Gavlrekanterne, øverste sidevægsgbjælker + tagbjælkerne - Le pignon, les dernières madriers + la panne faitière + les pannes intermédiaires - Il frontone o testata, le ultime tavolette delle pareti laterali + l'arcareccio del colmo +travi principali

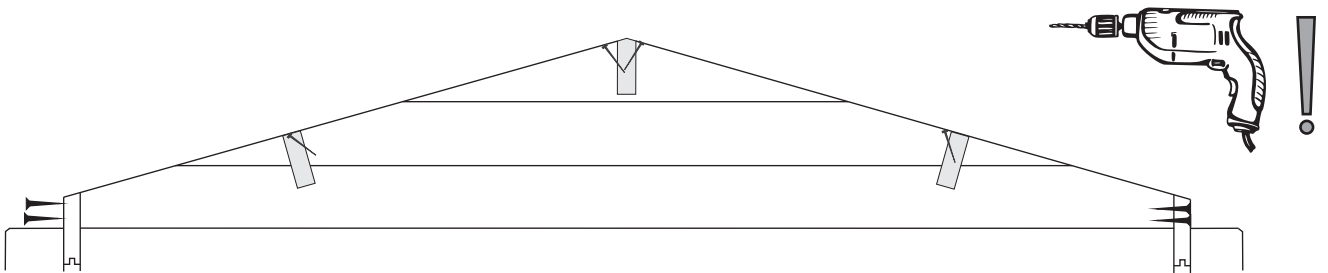
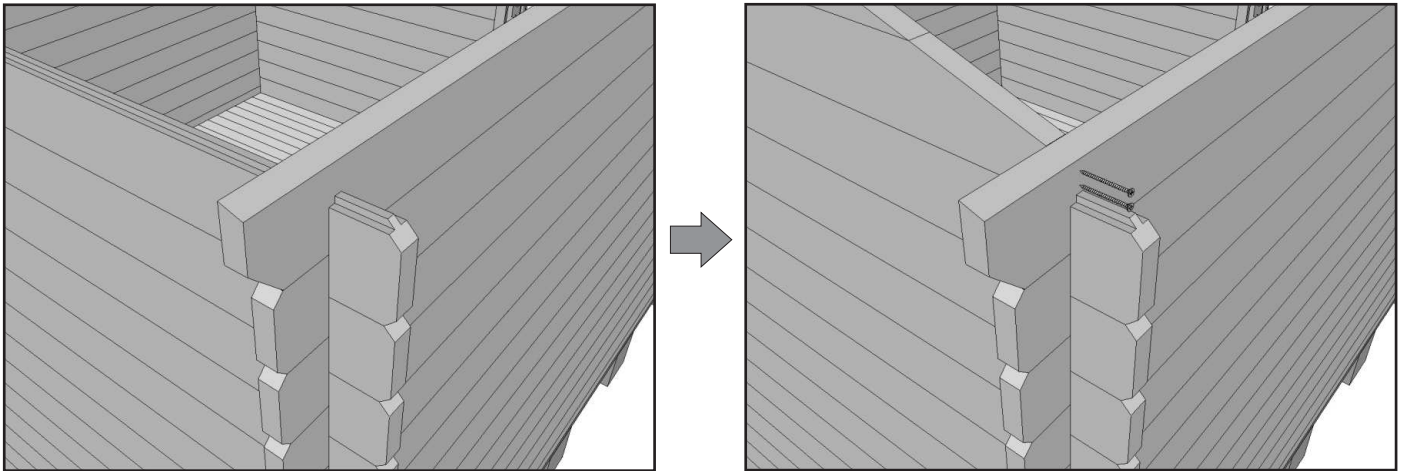

11. Kattolautojen asentaminen - Assembling the roof boards - Montering av takbrädorna -
 Montering af tagbrædderne - La pose des voliges -
 La posa dei listelli del tetto
 Katuselaudade paigaldus

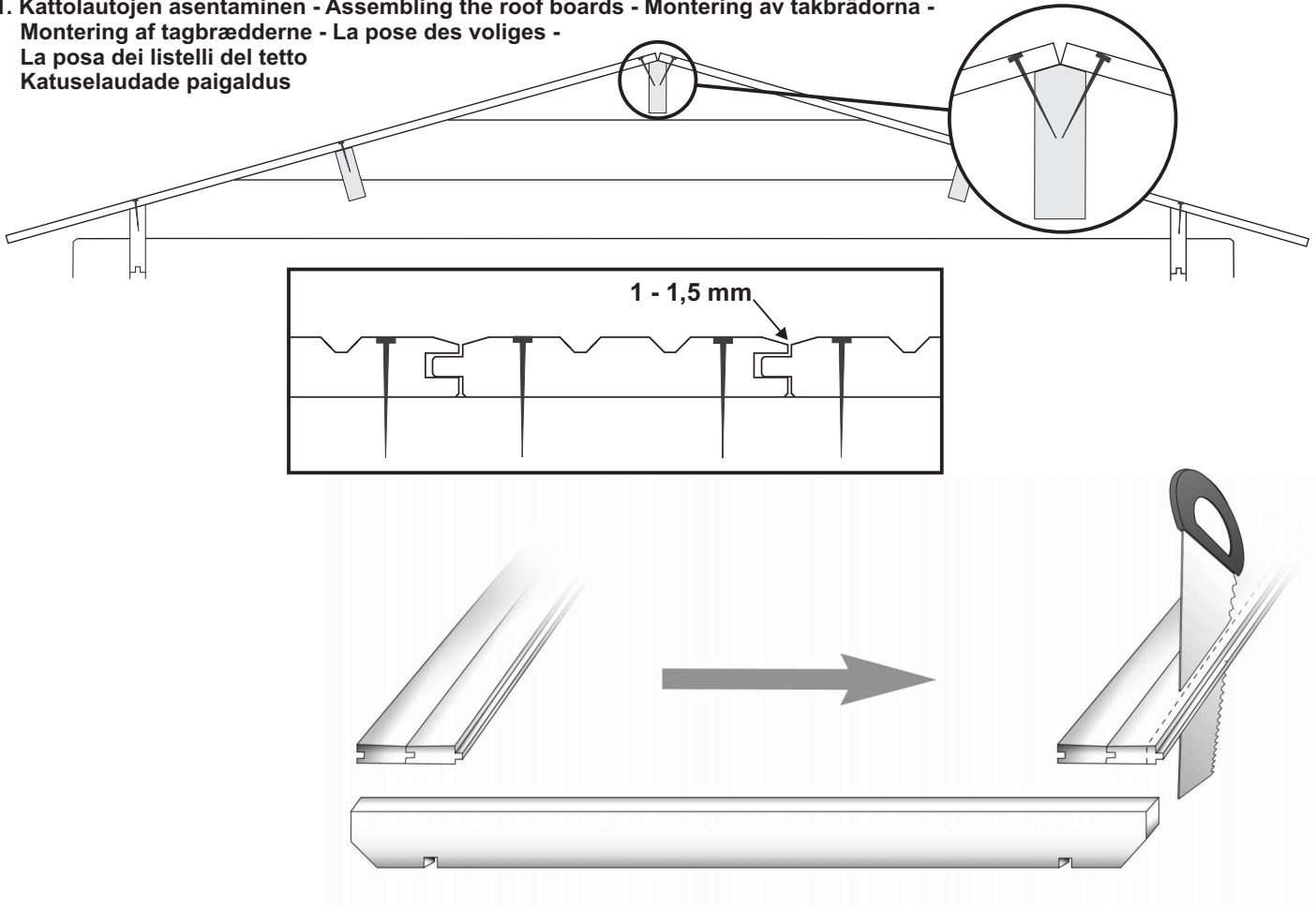

11a. Kattolaudat kahta pituutta - Roof boards in two lengths -
Takbrädorna i två längder - Les voliges deux tailles -
Tavolette per il tetto due misure

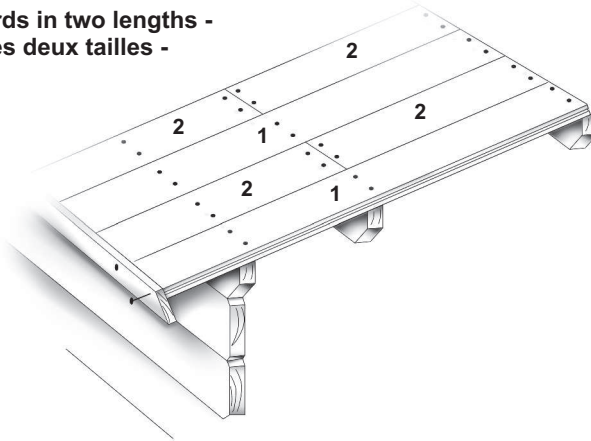

12. Rästslautojen asentaminen - Assembling the fascia boards - Montering av gavel- och takfotsbrädorna samt
vindskivorna - Montering af sternbrædder og dæklister - La pose des planches de rive - La posa delle assi di
rivestimento della grondaia

A

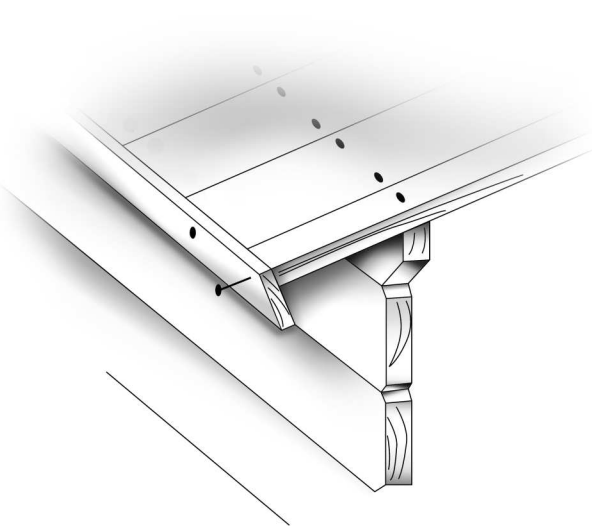

B

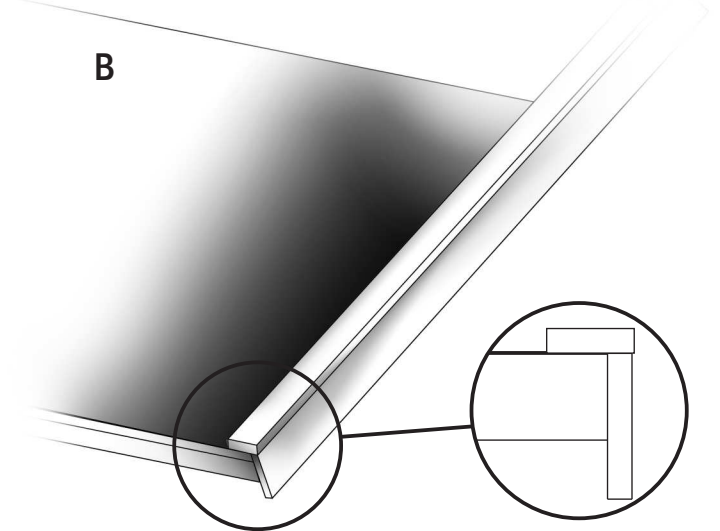

13. Rullahuovan asentaminen - Installing roofing felt - Montering av takfilt - Pålægning af tagpap -
La pose du feutre bitume - La posa della guaina feltro bitumato

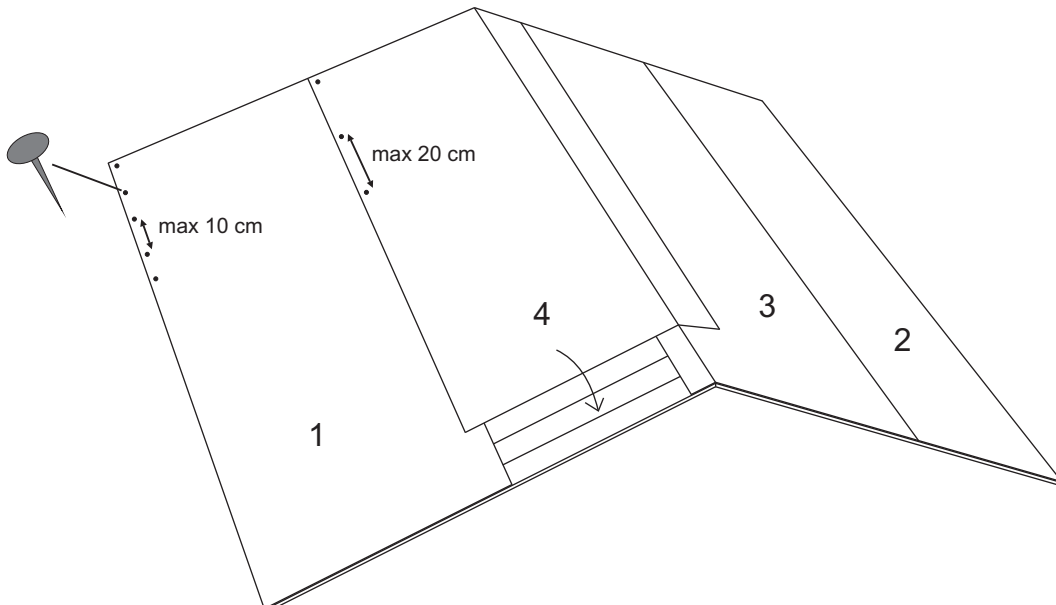

14. Palahuovan asentaminen - Installing roofing shingles - Montering av takplattor - Montering af shingles-plader -
 La pose des shingles - La posa delle tegole bitumate (shingles)

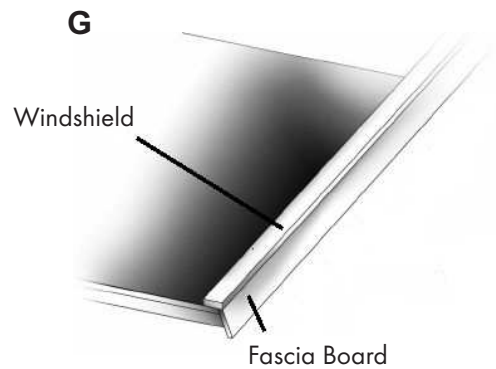
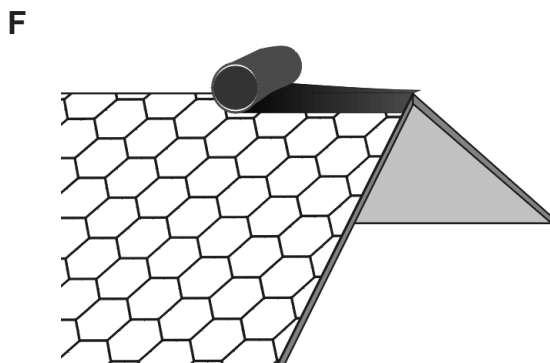
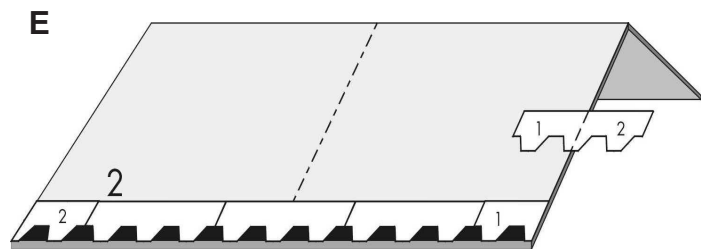
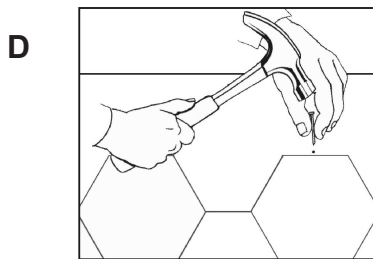
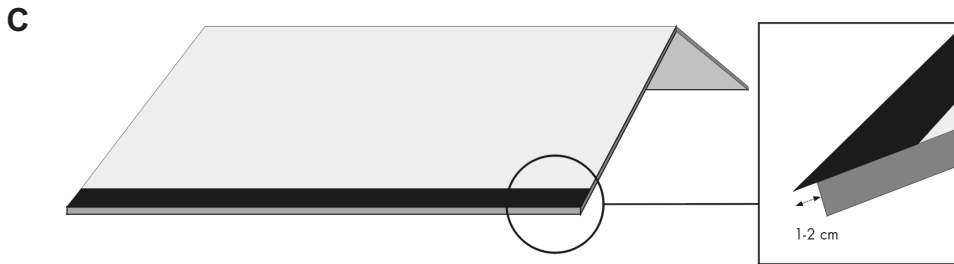
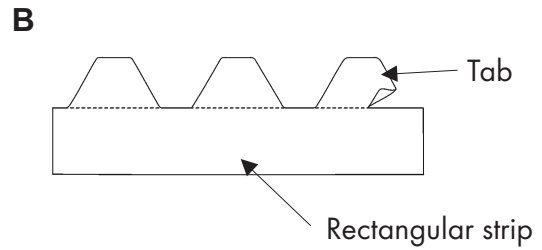
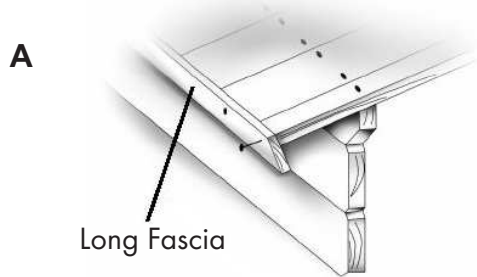



15. Myrskylistat 19 mm mökeissä - Storm battens in 19 mm cabins - Stormlisterna på 19 mm stugor - Stormlisterne i 19 mm bjælkehuse - Lattes de tempête dans les abris 19 mm - Listelli di tempesta nelle casette 19 mm - Tormiliistud 19 mm aiamaajades

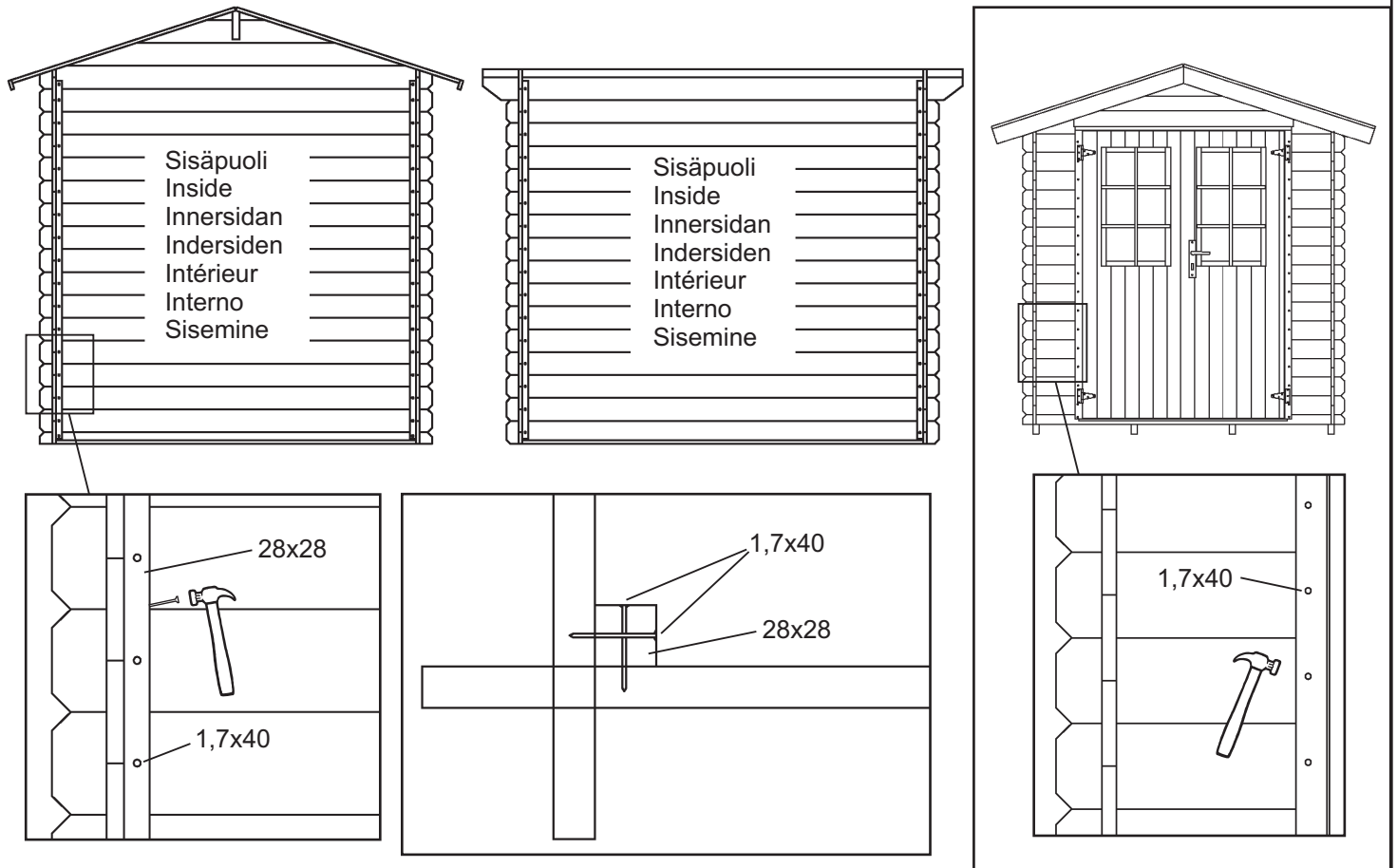

16. Myrskylistat 21 - 44 mm mökeissä - Storm battens in 21 - 44 mm cabins - Stormlisterna på 21 - 44 mm stugor - Stormlisterne i 21 - 44 mm bjælkehuse - Lattes de tempête dans les abris 21-44 mm - Listelli di tempesta nelle casette 21-44 mm

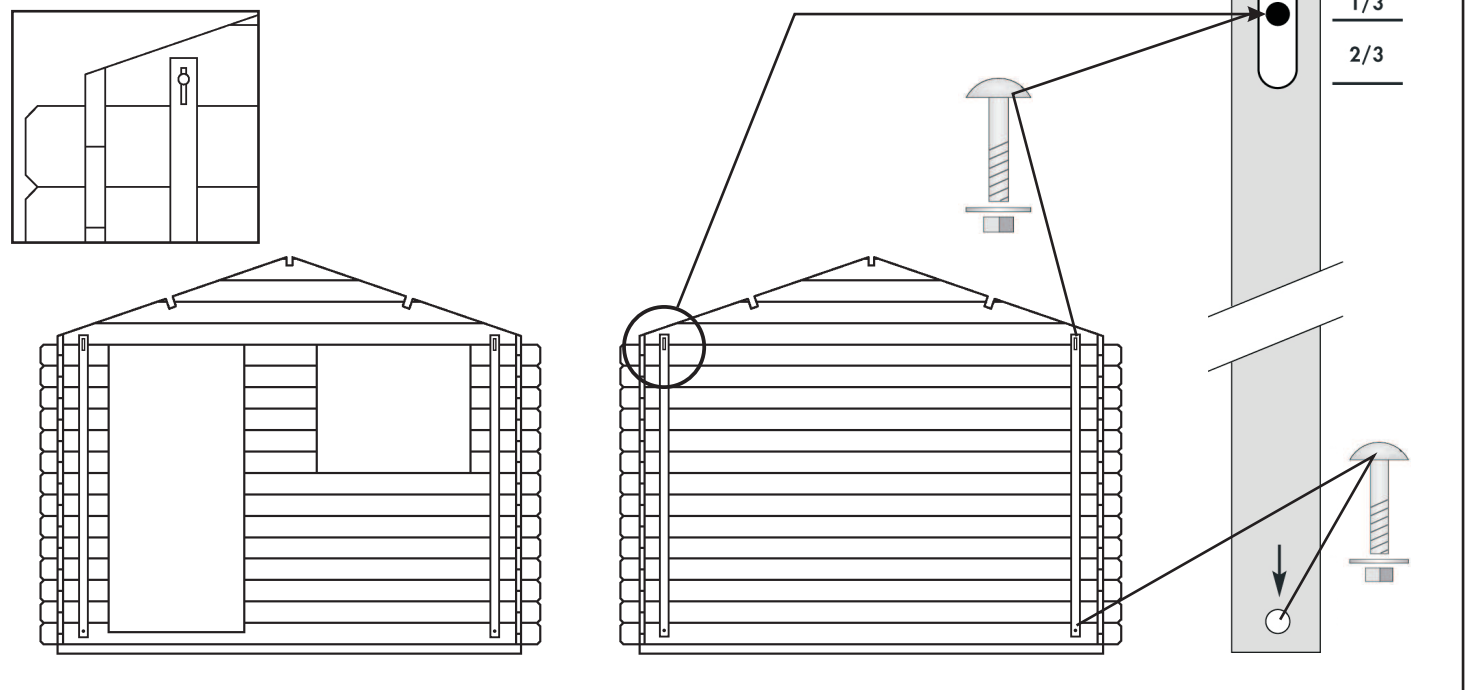

17. Kierretangot - Threaded rods - Gängstängerna - Gevindstænger - Tige filetée - Puntone di fissaggio

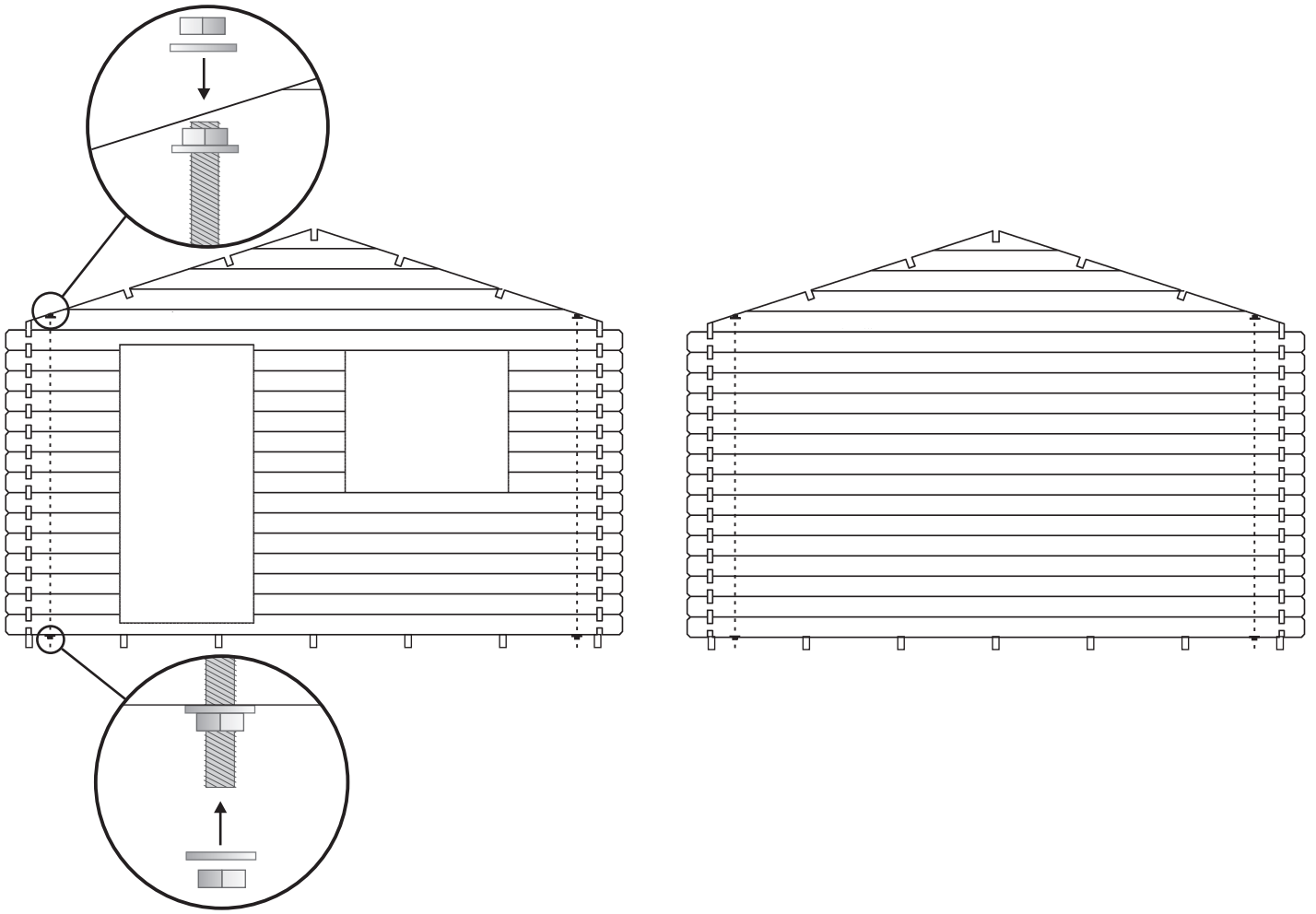

18. Ikkunaristikot - Window lattice - Fönsterspröjs - Vinduessprosser - Les croisillons des fenêtres -
 Le traverse in legno delle finestre

